

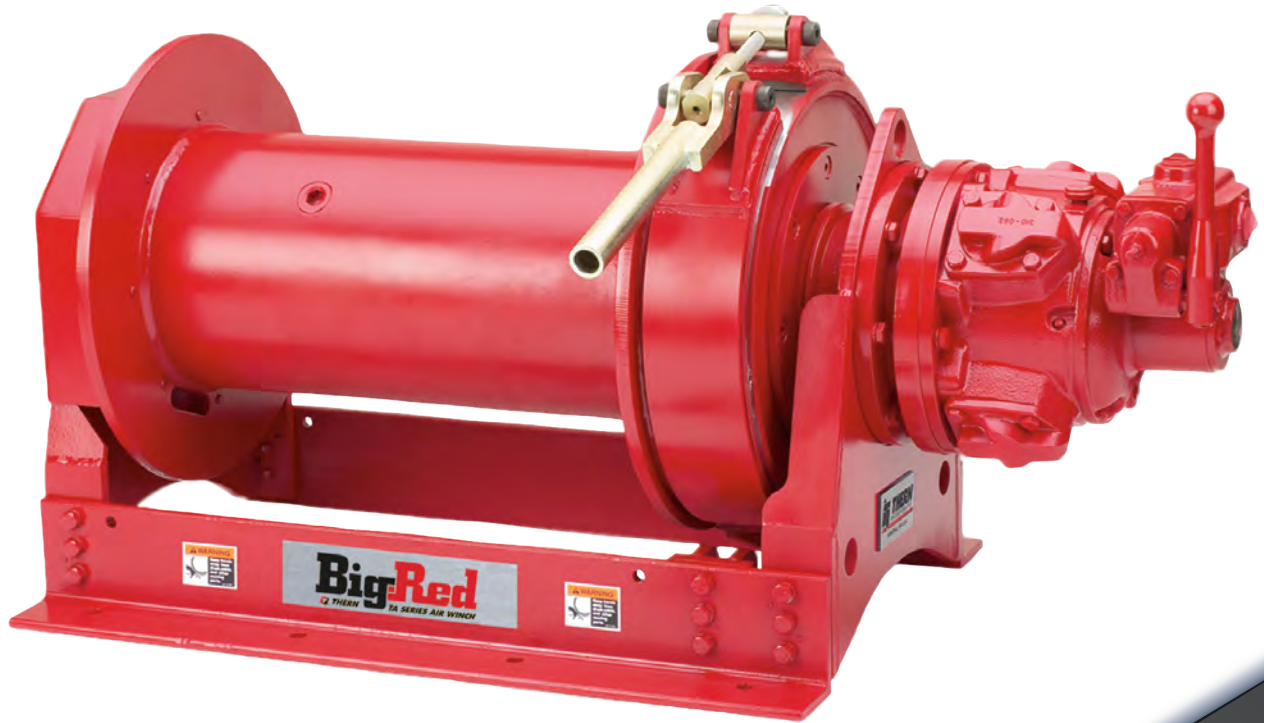

HEAVY-DUTY AIR WINCH

BIG RED SERIES



thern.com
(507) 454-2996

BIG RED SERIES

HEAVY-DUTY AIR WINCHES



POWER & VERSATILITY

Configured Your Way to Suit any Job

The Big Red Series of air winches (7,200 to 37,000 pounds) is designed to lift, lower, pull, or position heavy loads in the harshest environments. Numerous options and accessories allow customization to meet your specific needs—but at off-the-shelf lead-times. A heavy-duty radial piston motor and multiple control and brake configurations make it perfect for marine, mining, construction, and oil and gas applications.

Robust Frame & Drum

- Welded steel frame and drum components provide superior durability
- Multiple drum widths increase rope life and accommodate various load travel distances and fleet angles

ASME B30.7 Compliance Available

- Contact Thern for details



Product Shown: TA10

Durable Gears & Compact Gearbox Design

- Gearbox location within the drum and high-efficiency planetary gearing provides high torque and enhanced power in a compact envelope
- Oil bath, featuring double-lip seals, provides continuous lubrication for gears, minimizes heat, and increases service life while resisting contamination

Multiple Brake Configurations

- Lever engaged/disengaged band brake for simple operation
- Automatic band brake enhances operator autonomy
- Sealed, automatic multi-disk brake, featuring continuous lubrication, allows extended duty cycles and resists contamination—ideal for corrosive and dirty environments

Power Dense Radial Piston Motor

- Internally lubricated for reliability and exceptionally long service life
- Reversible, high-torque design allows precise yet flexible operation
- Powerful operation allows high capacity and faster line speeds

Flexible Operation & Control

- Variable-speed control promotes smooth operation—perfect for precise spotting and long lifts
- Available manual-control lever simplifies operation
- Operator-friendly, remote pendant control (up to 50 feet)
- reduces operator fatigue (due to vibration) and promotes freedom of movement for better load/task visibility

PERFORMANCE

Series	IMPERIAL				
	Load Rating	Power Supply	Line Speed	Drum Capacity	Clutch
TA2	7,200 lbs	7.1 hp	30 fpm	1,270 ft	No
TA2H	3,600 lbs	7.1 hp	61 fpm	1,270 ft	No
TA2.5	7,200 lbs	18.3 hp	79 fpm	860 ft	No
TA5	18,000 lbs	17.8 hp	30 fpm	1,520 ft	No
TA7	23,600 lbs	14.4 hp	19 fpm	1,730 ft	No
TA10	37,000 lbs	27 hp	20 fpm	2,780 ft	No

Series	METRIC				
	Load Rating	Power Supply	Line Speed	Drum Capacity	Clutch
TA2	3,265 kg	5.3 kW	9 mpm	385 m	No
TA2H	1,630 kg	5.3 kW	18.5 mpm	385 m	No
TA2.5	3,265 kg	13.6 kW	24 mpm	260 m	No
TA5	8,160 kg	13.3 kW	9 mpm	460 m	No
TA7	10,700 kg	10.7 kW	5.5 mpm	525 m	No
TA10	16,780 kg	20 kW	6 mpm	845 m	No



NOTICE: These products are not for lifting people or things over people.

Refer to technical pages for detailed performance information.

BIG RED SERIES AIR WINCHES

Model TA2 Series, TA2H Series, TA2.5 Series, TA5 Series, and TA7 Series

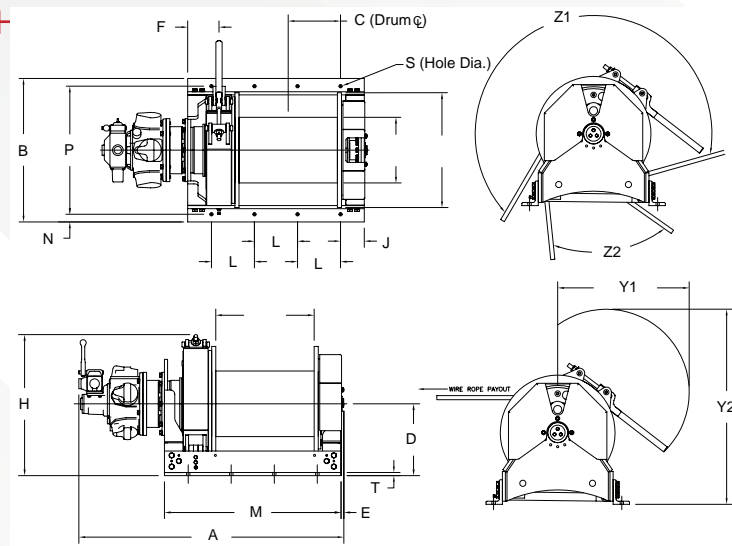

BIG RED TA Series UTILITY RATED Air Winch Performance Characteristics

	TA2 Series		TA2H Series		TA2.5 Series		TA5 Series		TA7 Series	
Load Rating 1st Layer	7,200 lb	3,265 kg	3,600 lb	1,632 kg	7,200 lb	3,265 kg	18,000 lb	8,164 kg	23,600 lb	10,704 kg
Load Rating Mid Drum	5,700 lb	2,585 kg	2,900 lb	1,315 kg	5,900 lb	2,676 kg	14,000 lb	6,350 kg	19,000 lb	8,618 kg
Load Rating Full Drum	4,700 lb	2,131 kg	2,400 lb	1,088 kg	5,000 lb	2,268 kg	11,500 lb	5,216 kg	15,900 lb	7,212 kg
Line Speed 1st Layer *	30 fpm	9.1 m/min	61 fpm	18.6 m/min	79 fpm	24.1 m/min	30 fpm	9.1 m/min	19 fpm	5.8 m/min
Line Speed Mid Drum *	38 fpm	11.6 m/min	77 fpm	23.5 m/min	96 fpm	29.3 m/min	39 fpm	11.9 m/min	24 fpm	7.3 m/min
Line Speed Full Drum *	46 fpm	14.0 m/min	94 fpm	28.7 m/min	114 fpm	34.7 m/min	47 fpm	14.3 m/min	29 fpm	8.8 m/min
Input HP	7.1 hp	7.1 hp	7.1 hp	7.1 hp	18.3 hp	18.3 hp	17.8 hp	17.8 hp	14.4 hp	14.4 hp
Max. Stall Pull 1st Layer	9,000 lb	4,082 kg	4,500 lb **	2,041 kg **	11,000 lb	4,989 kg	33,000 lb	14,968 kg	38,000 lb	17,236 kg
Pressure	90 psi	6.3 kgf/cm ²	90 psi	6.3 kgf/cm ²	90 psi	6.3 kgf/cm ²	90 psi	6.3 kgf/cm ²	90 psi	6.3 kgf/cm ²
Flow	250 scfm	7.0 m ³ /min	250 scfm	7.0 m ³ /min	600 scfm	17.0 m ³ /min	550 scfm	15.6 m ³ /min	550 scfm	15.6 m ³ /min
Pipe Inlet Size	1 in	25.4 mm	1 in	25.4 mm	1.5 in	38.1 mm	1.5 in	38.1 mm	1.5 in	38.1 mm
Hose Size	1.25 in	31.8 mm	1.25 in	31.8 mm	1.5 in	38.1 mm	1.5 in	38.1 mm	1.5 in	38.1 mm

* Line speeds vary based on conditions of air supply. Line speeds may run up to 20% slower when configured with auto band brakes.
** Estimated value.

BIG RED TA Series UTILITY RATED Air Winch Drum Capacities*

Model	Wire Rope		Drum Width																
			16 in (407 mm)				24 in (610 mm)				30 in (762 mm)				36 in (915 mm)				
	Diameter	Breaking Strength**	1st Layer	Mid Drum	Full Drum	1st Layer	Mid Drum	Full Drum	1st Layer	Mid Drum	Full Drum	1st Layer	Mid Drum	Full Drum	1st Layer	Mid Drum	Full Drum		
	(in)	(mm)	(lb)	(kg)	(ft)	(m)	(ft)	(m)	(ft)	(m)	(ft)	(m)	(ft)	(m)	(ft)	(m)	(ft)	(m)	
TA2	0.5	12.7	26,600	12,065	83	25	380	115	850	259	130	39	570	173	1,270	387	—	—	—
TA2H	0.5	12.7	26,600	12,065	83	25	380	115	850	259	130	39	570	173	1,270	387	—	—	—
TA2.5	0.63	16.0	41,200	18,688	71	21	260	79	580	176	110	33	390	118	860	262	—	—	—
TA5	0.75	19.1	58,800	26,671	72	21	360	109	810	246	120	36	550	167	1,210	368	150	45	680
TA7	0.88	22.4	79,600	36,106	—	—	—	—	—	—	120	36	520	158	1,150	350	160	48	650

* Drum capacity is based on a drum flange clearance at the top layer per ASME B30.7
** Values based on 6x37 IWRC EIPS wire rope.

Minimum Fleet Angle Distances

Model	Drum Diameter		Flange Diameter		Drum Width		Fleet Angle Distance	
	(in)	(mm)	(in)	(mm)	(in)	(mm)	(ft)	(m)
TA2-16	11.50	292	20	508	16	406	26	8
TA2-24	11.50	292	20	508	24	610	39	12
TA2H-16	11.50	292	20	508	16	406	26	8
TA2H-24	11.50	292	20	508	24	610	39	12
TA2.5-16	12.75	324	21	533	16	406	26	8
TA2.5-24	12.75	324	21	533	24	610	39	12
TA5-16	16	406	28	711	16	406	26	8
TA5-24	16	406	28	711	24	610	39	12
TA5-30	16	406	28	711	30	762	48	15
TA7-24	20	508	33	838	24	610	39	12
TA7-30	20	508	33	838	30	762	48	15
TA7-36	20	508	33	838	36	914	58	18

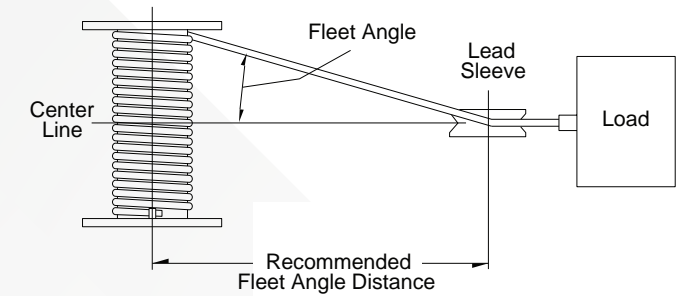

BIG RED TA Series UTILITY RATED Air Winch Dimensions

Model	A		B		C		D		E		F		H		J		L	
	(in)	(mm)	(in)	(mm)	(in)	(mm)	(in)	(mm)	(in)	(mm)	(in)	(mm)	(in)	(mm)	(in)	(mm)	(in)	(mm)
TA2-16	44	1,118	24	610	9.06	230	14	356	0.54	14	5.25	133	28.50	724	2.88	73	7.50	191
TA2-24	52	1,321	24	610	12.81	325	14	356	0.54	14	5.25	133	28.50	724	3.13	80	10	254
TA2H-16	44	1,118	24	610	9.06	230	14	356	0.54	14	5.25	133	28.50	724	2.88	73	7.50	191
TA2H-24	52	1,321	24	610	12.81	325	14	356	0.54	14	5.25	133	28.50	724	3.13	80	10	254
TA2.5-16	50	1,270	24	610	9	229	14	356	0.73	19	5.25	133	30	762	2.88	73	7.50	191
TA2.5-24	58	1,473	24	610	12.75	324	14	356	0.73	19	5.25	133	30	762	3.13	80	10	254
TA5-16	57	1,448	35	889	10.53	267	17.50	445	0.68	17	7.75	197	34.50	876	4.03	102	9	229
TA5-24	65	1,651	35	889	12.78	325	17.50	445	0.68	17	7.75	197	34.50	876	5.78	147	10.5	267
TA5-30	71	1,803	35	889	17.03	433	17.50	445	0.68	17	7.75	197	34.50	876	4.53	115	10	254
TA7-24	69	1,753	38	965	15.41	391	20	508	1	25	9.25	235	37	940	5.38	137	9	229
TA7-30	75	1,905	38	965	17.41	442	20	508	1	25	9.25	235	37	940	6.38	162	10	254
TA7-36	81	2,057	38	965	19.41	493	20	508	1	25	9.25	235	37	940	7.38	187	11	279

	M		N		P		S (hole dia.)		T		Y1		Y2		Z1		Z2		Bolts	Bolt Size	Weight *	
	(in)	(mm)	(in)	(mm)	(in)	(mm)	(in)	(mm)	(in)	(mm)	(in)	(mm)	(in)	(mm)	(degrees)	(degrees)	(qty)	(in - G8)			(lb)	(kg)
TA2-16	28.5	724	2	51	20	508	0.69	18	0.50	13	20	508	37	940	223	34	8	5/8	990	450		
TA2-24	36.5	927	2	51	20	508	0.69	18	0.50	13	20	508	37	940	223	34	8	5/8	1,080	490		
TA2H-16	28.5	724	2	51	20	508	0.69	18	0.50	13	20	508	37	940	223	34	8	5/8	990	450		
TA2H-24	36.5	927	2	51	20	508	0.69	18	0.50	13	20	508	37	940	223	34	8	5/8	1,080	490		
TA2.5-16	28.5	724	2	51	20	508	0.69	18	0.50	13	20	508	37	940	228	27	8	5/8	1,315	597		
TA2.5-24	36.5	927	2	51	20	508	0.69	18	0.50	13	20	508	37	940	228	27	8	5/8	1,400	636		
TA5-16	35.5	902	1.88	48	31.25	794	0.81	21	0.75	19	32.5	826	48	1,219	224	50	8	3/4	2,585	1,173		
TA5-24	43.5	1,105	1.88	48	31.25	794	0.81	21	0.75	19	32.5	826	48	1,219	224	50	8	3/4	2,745	1,246		
TA5-30	49.5	1,257	1.88	48	31.25	794	0.81	21	0.75	19	32.5	826	48	1,219	224	50	10	3/4	2,870	1,302		
TA7-24	47	1,194	1.88	48	34.25	870	0.94	24	0.75	19	32	813	51	1,295	210	39	10	7/8	3,600	1,633		
TA7-30	53	1,346	1.88	48	34.25	870	0.94	24	0.75	19	32	813	51	1,295	210	39	10	7/8	3,765	1,708		
TA7-36	59	1,499	1.88	48	34.25	870	0.94	24	0.75	19	32	813	51	1,295	210	39	10	7/8	3,965	1,799		

Dimensions are for reference only and subject to change without notice. Please contact Them for exact dimensions.

Model TA10 Series

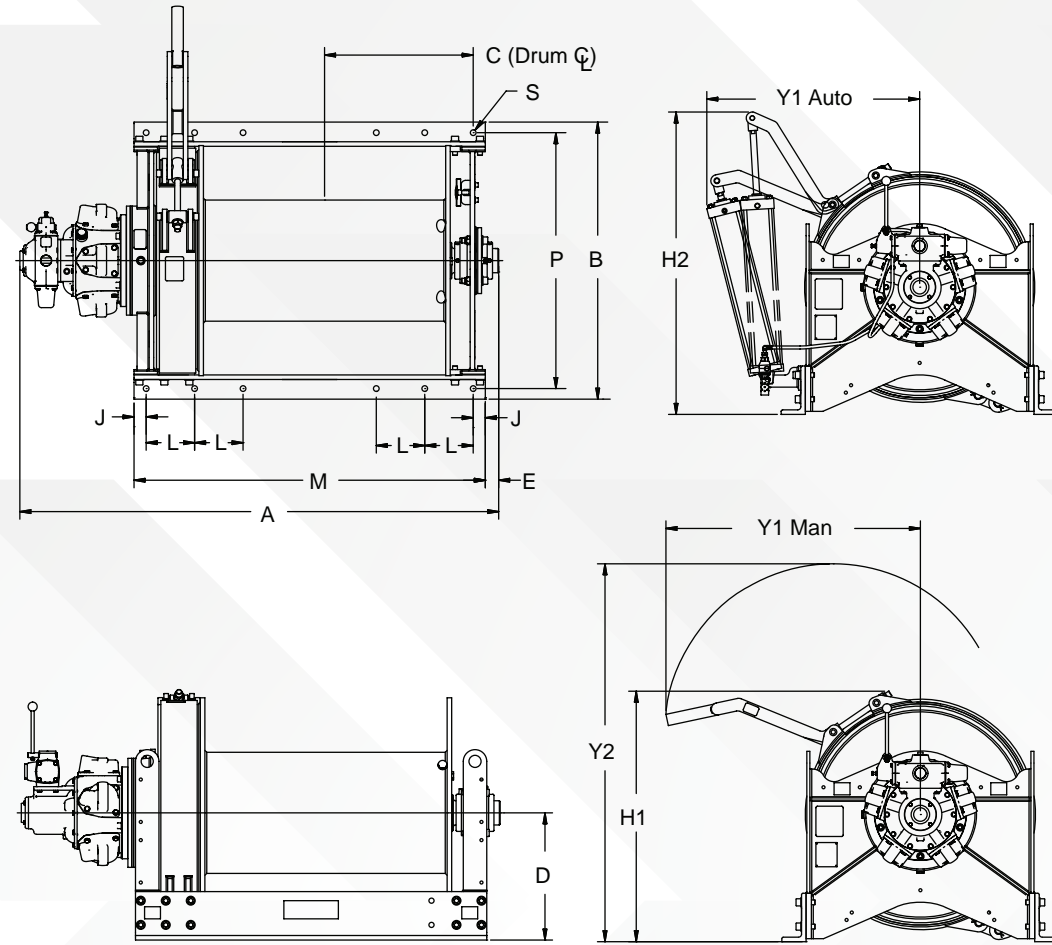

BIG RED TA10 Series Performance Characteristics

TA10 Series		
Load Rating 1st Layer	37,000 lb	16,783 kg
Load Rating Mid Drum	27,400 lb	12,428 kg
Load Rating Full Drum	21,800 lb	9,888 kg
Line Speed 1st Layer *	20 fpm	6.1 m/min
Line Speed Mid Drum *	27 fpm	8.2 m/min
Line Speed Full Drum *	34 fpm	10.4 m/min
Input HP	27 hp	27 hp
Max. Stall Pull 1st Layer	63,000 lb **	28,576 kg
Pressure	90 psi	6.3 kgf/cm ²
Flow	900 scfm	25 m ³ /min
Pipe Inlet Size	1.5 in	38.1 mm
Hose Size	1.5 in	38.1 mm

* Line speeds vary based on conditions of air supply. Line speeds may run up to 20% slower when configured with auto band brakes.
** Estimated value.

BIG RED TA10 Series Fleet Angle Requirements

Model	Drum Diameter		Flange Diameter		Drum Width		Fleet Angle Distance	
	(in)	(mm)	(in)	(mm)	(in)	(mm)	(ft)	(m)
TA10-30	20	508	38	965	30	762	48	15
TA10-40	20	508	38	965	40	1,016	64	20
TA10-60	20	508	38	965	60	1,524	95	29

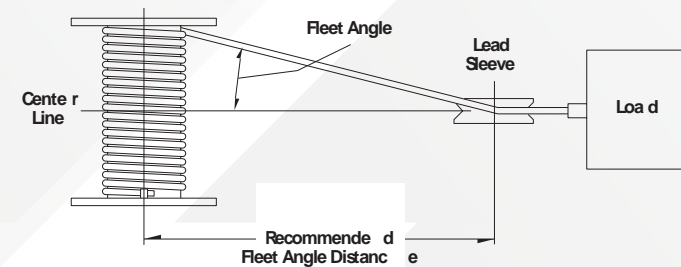

BIG RED TA10 Series Air Winch Drum Capacities*

Model	Wire Rope		Drum Width								
			30 in (762 mm)			40 in (1,016 mm)			60 in (1,524 mm)		
	Diameter	Breaking Strength**	1st Layer	Mid Drum	Full Drum	1st Layer	Mid Drum	Full Drum	1st Layer	Mid Drum	Full Drum
	(in) (mm)	(lb) (kg)	(ft) (m)	(ft) (m)	(ft) (m)	(ft) (m)	(ft) (m)	(ft) (m)	(ft) (m)	(ft) (m)	(ft) (m)
TA10	1-1/8 28.7	130,000 58,968	120 36	620 188	1,390 423	160 48	830 252	1,850 563	260 79	1,250 381	2,780 847

* Drum capacity is based on a drum flange clearance at the top layer per ASME B30.7

** Values based on 6x37 IWRC EIPS wire rope.

BIG RED TA10 Series Air Winch Dimensions

Model	A		B		C		D		E		H1		H2		J		L	
	(in)	(mm)	(in)	(mm)	(in)	(mm)	(in)	(mm)	(in)	(mm)	(in)	(mm)	(in)	(mm)	(in)	(mm)	(lb)	(kg)
TA10-30	69	1,753	45.75	1,162	19.5	495	21	533	2.25	57	41.50	1,054	50	1,270	2	51	8	203
TA10-40	79	2,007	45.75	1,162	24.5	622	21	533	2.25	57	41.50	1,054	50	1,270	2	51	8	203
TA10-60	99	2,515	45.75	1,162	34.5	876	21	533	2.25	57	41.50	1,054	50	1,270	2	51	8	203

	M		P		S (hole diameter)		Y1 (man)		Y1 (auto)		Y2		# Bolts	Bolt Size	Weight *	
	(in)	(mm)	(in)	(mm)	(in)	(mm)	(in)	(mm)	(in)	(mm)	(in)	(mm)			(in)	(lb)
TA10-30	48	1,219	42.25	1,073	.94	24	42	1,067	35.25	895	62.5	1,588	12	7/8 - G8	3,220	1,461
TA10-40	58	1,473	42.25	1,073	.94	24	42	1,067	35.25	895	62.5	1,588	12	7/8 - G8	3,515	1,595
TA10-60	78	1,981	42.25	1,073	.94	24	42	1,067	35.25	895	62.5	1,588	12	7/8 - G8	4,105	1,862

* Weights based on MX1 configuration. Weights subject to change with configurations. Dimensions are for reference only and subject to change without notice. Please contact Thern for exact dimensions.

MADE IN USA 

Thern, Incorporated

World Headquarters
5712 Industrial Park Road Winona, MN USA
Toll Free: 1-800-843-7648
Phone: 1-507-454-2996
www.thern.com

Thern Europe

Amsterdam Schiphol Tetra
Siriusdreef 17-27, 2132 WT Hoofddorp
The Netherlands
Phone: +31-546-898380
europa@thern.com